

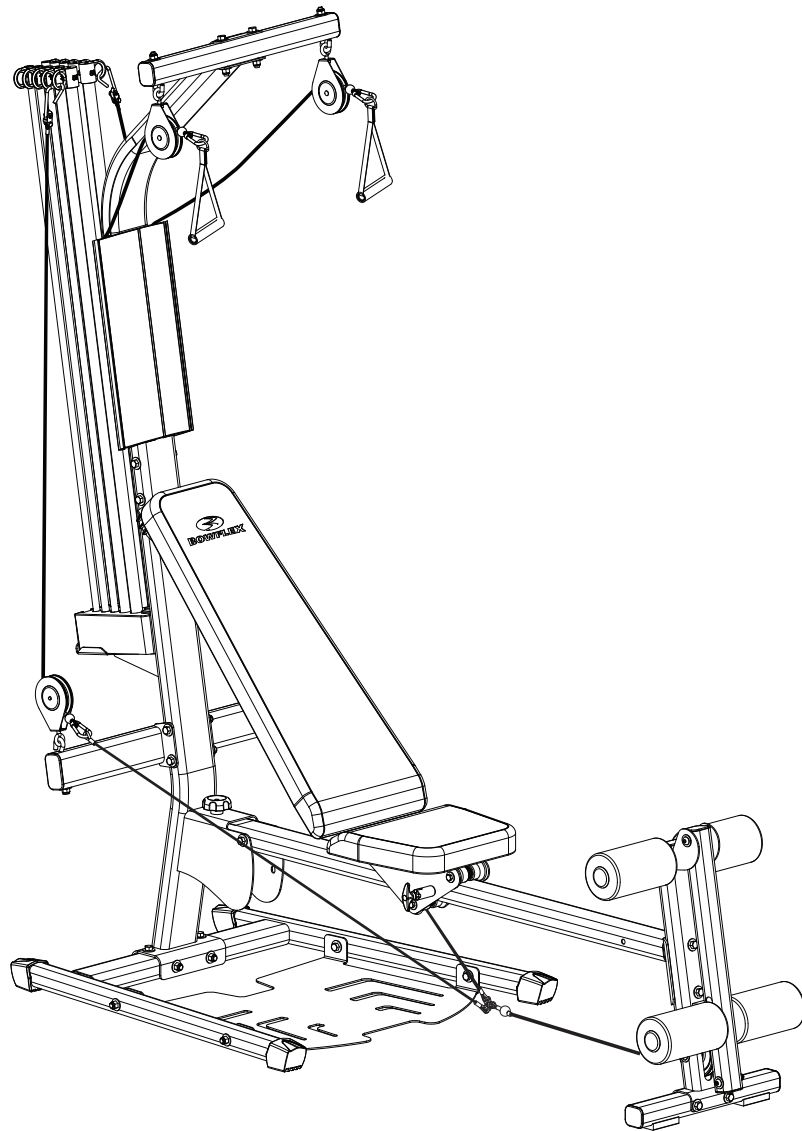

# PR1000 Home Gym



## Assembly Manual



# Table of Contents

<b>Before Assembly</b> .....	2	Apply the Cable Clip .....	15
<b>Tools</b> .....	2	Attach the Rod Pack .....	16
<b>Important Safety Instructions</b> .....	3	Chest Bar with Pulleys.....	17
<b>Hardware</b> .....	4	Leg Extension Rollers.....	18
<b>Parts</b> .....	5	Attach the Bench .....	19
<b>Assembly</b> .....	7	Attach Placard .....	20
Attach the Lower Lat Tower to the Base .....	7	Level the Machine.....	21
Secure the Lower Lat Tower to the Base .....	8	Connect the Cables to the PowerRod® Unit, Chest Bar, and Handgrips.....	22
Assemble the Seat Rail.....	9	Connect the Cables from the Chest Bar and Lat Cross Bar to the Handgrips.....	23
Assemble the Leg Extension.....	10	Connect the Cables from the Chest Bar to the Leg Extension .....	24
Attach the Seat Rail to the Leg Extension .....	11	Final Inspection.....	24
Attach the Seat Rail to the Base Assembly .....	12	<b>Contacts</b> .....	<b>28</b>
Upper Lat Tower.....	13		
Attach the Upper Lat Tower to the Base Assembly .....	14		

## Before Assembly

Select where you are going to locate your Bowflex® home gym carefully. The best location is on a hard, level surface. For best results, assemble your home gym in the location where you intend to use it. For safe operation, allow a workout area of at least 127" x 82" (3.3m x 2.1m) of free space.

Follow these basic tips when assembling your home gym.

1. Collect all the pieces needed for each assembly step.
2. Turn all the bolts and locknuts toward the right to tighten. Turn towards the left to loosen.
3. Use a combination wrench to grip the locknut when you tighten a bolt that has a locknut to make sure it is tight.
4. You may find the use of a utility knife or scissors beneficial during the unpacking and assembly process.
5. Carefully lift pieces when attaching. Look through the bolt holes to help guide bolt placement.
6. Assembly requires 2 people.

**NOTICE:** Leave all of the cables wrapped and bagged until the Bowflex® home gym is completely assembled.

## Tools

- (2) Adjustable Wrenches (not included)
- Phillips Head Screwdriver (not included)

To validate warranty support, keep the original proof of purchase and record the following information:

**Serial Number** \_\_\_\_\_

**Date of Purchase** \_\_\_\_\_

To register your product warranty, go to: [www.bowflex.com/register](http://www.bowflex.com/register)

Or call 1 (800) 605-3369.

If you have questions or problems with your product, please call 1 (800) NAUTILUS (628-8458).

# Important Safety Instructions



This icon means a potentially hazardous situation which, if not avoided, could result in death or serious injury.

## Obey the following warnings:













Read and understand all warnings on this machine.

Carefully read and understand the Assembly Manual.

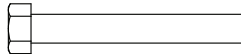
- Keep bystanders and children away from the product you are assembling at all times.
- Do not assemble this machine outdoors or in a wet or moist location.
- Make sure assembly is done in an appropriate work space away from foot traffic and exposure to bystanders.
- Some components of the machine can be heavy or awkward. Use a second person when doing the assembly steps involving these parts. Do not do steps that involve heavy lifting or awkward movements on your own.
- Set up this machine on a solid, level, horizontal surface.
- Do not try to change the design or functionality of this machine. This could compromise the safety and can void the warranty.
- If replacement parts are necessary use only genuine Nautilus® replacement parts and hardware. Failure to use genuine replacement parts can cause a risk to users, keep the machine from operating correctly or void the warranty.
- Do not use the machine until it has been fully assembled and inspected for correct performance in accordance with the Owner's Manual.
- Read and understand the complete Owner's Manual supplied with this machine before first use. Keep the Owner's and Assembly Manuals for future reference.
- Do all assembly steps in the sequence given. Incorrect assembly can lead to injury.

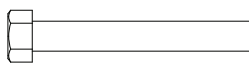
# Hardware

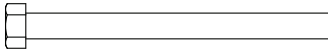
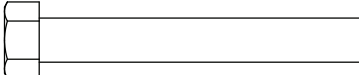
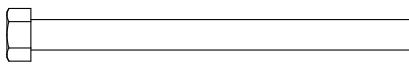
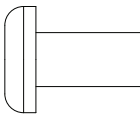
(Hardware not actual size)

<p>Qty. 4</p> 	<p>Item #1 5/16" x 3/4" Hex Head Bolt</p>	<p>Qty. 5</p> 	<p>Item #8 1/4" Washer</p>
<p>Qty. 8</p> 	<p>Item #2 3/8" x 3/4" Hex Head Bolt</p>	<p>Qty. 4</p> 	<p>Item #9 5/16" Washer</p>
<p>Qty. 2</p> 	<p>Item #3 3/8" x 2 3/4" Hex Head Bolt</p>	<p>Qty. 29</p> 	<p>Item #10 3/8" Washer</p>
<p>Qty. 4</p> 	<p>Item #4 3/8" x 3" Hex Head Bolt</p>	<p>Qty. 10</p> 	<p>Item #11 3/8" Nut</p>
<p>Qty. 2</p> 	<p>Item #5 3/8" x 4" Hex Head Bolt</p>	<p>Qty. 1</p> 	<p>Item #12 3/8" x 4 1/4" Hex Head Bolt</p>
<p>Qty. 2</p> 	<p>Item #6 3/8" x 5" Hex Head Bolt</p>	<p>Qty. 2</p> 	<p>Item #13 1/4" x 1" Phillips Head Bolt</p>
<p>Qty. 3</p> 	<p>Item #7 #10 x 1" Self Tapping Screw</p>		

# Parts

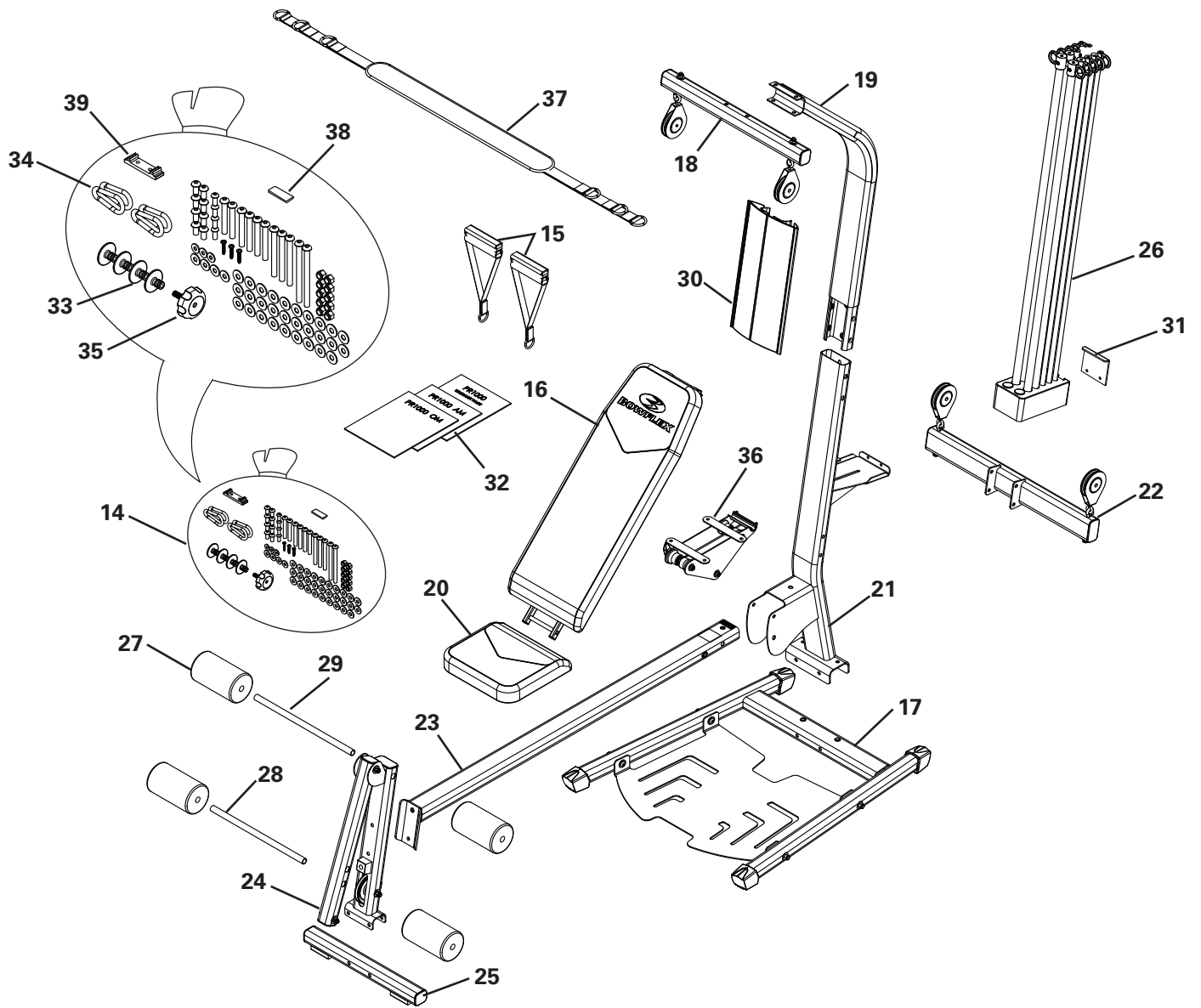

# Parts

Item #	Qty.	Description
14	1	Hardware Bag
15	1	Pair Handgrips
16	1	Bench
17	1	Base Platform
18	1	Lat Cross Bar
19	1	Upper Lat Tower
20	1	Sliding Seat
21	1	Lower Lat Tower
22	1	Chest Pulley Cross Bar
23	1	Seat Rail with Slider
24	1	Leg Extension
25	1	Leg Extension Base
26	1	Bowflex® Rod Pack

Item #	Qty.	Description
27	4	Foam Roller Pads
28	1	Short Roller Tube
29	1	Long Roller Tube
30	1	Exercise Placard
31	1	Rod Box End Plate
32	1	Manual Kit
33	4	End Caps
34	4	Clips
35	1	Threaded Knob
36	1	Seat Slider
37	1	Leg Press Belt
38	1	Rubber Pad
39	1	Cable Clip

# Assembly

## Step 1: Attach the Lower Lat Tower to the Base

### Parts

- Base Platform (#17)
- Lower Lat Tower (#21)

### Hardware

- (2) 3/8" x 3/4" Hex Head Bolts (#2)
- (2) 3/8" Washers (#10)

### Tools

- Adjustable Wrench (not included)

**1-1** Attach the Lower Lat Tower to the Base Platform with first set of bolts.

**Note:** Do not tighten hardware.

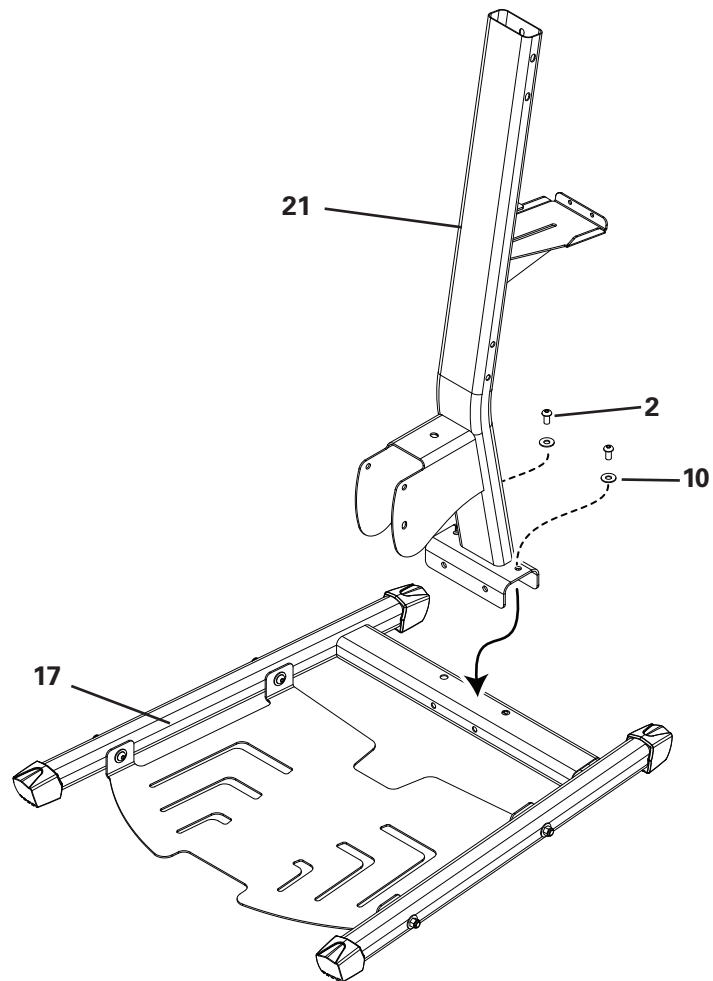

# Assembly

## Step 2: Secure the Upper Lat Tower to the Base

### Parts

- Completed Assembly (from step 1)

### Hardware

- (2) 3/8" x 4" Hex Head Bolts (#5)
- (4) 3/8" Washers (#10)
- (2) 3/8" Nuts (#11)

### Tools

- (2) Adjustable Wrenches (not included)

2-1 Install the second set of bolts and tighten all of the hardware.

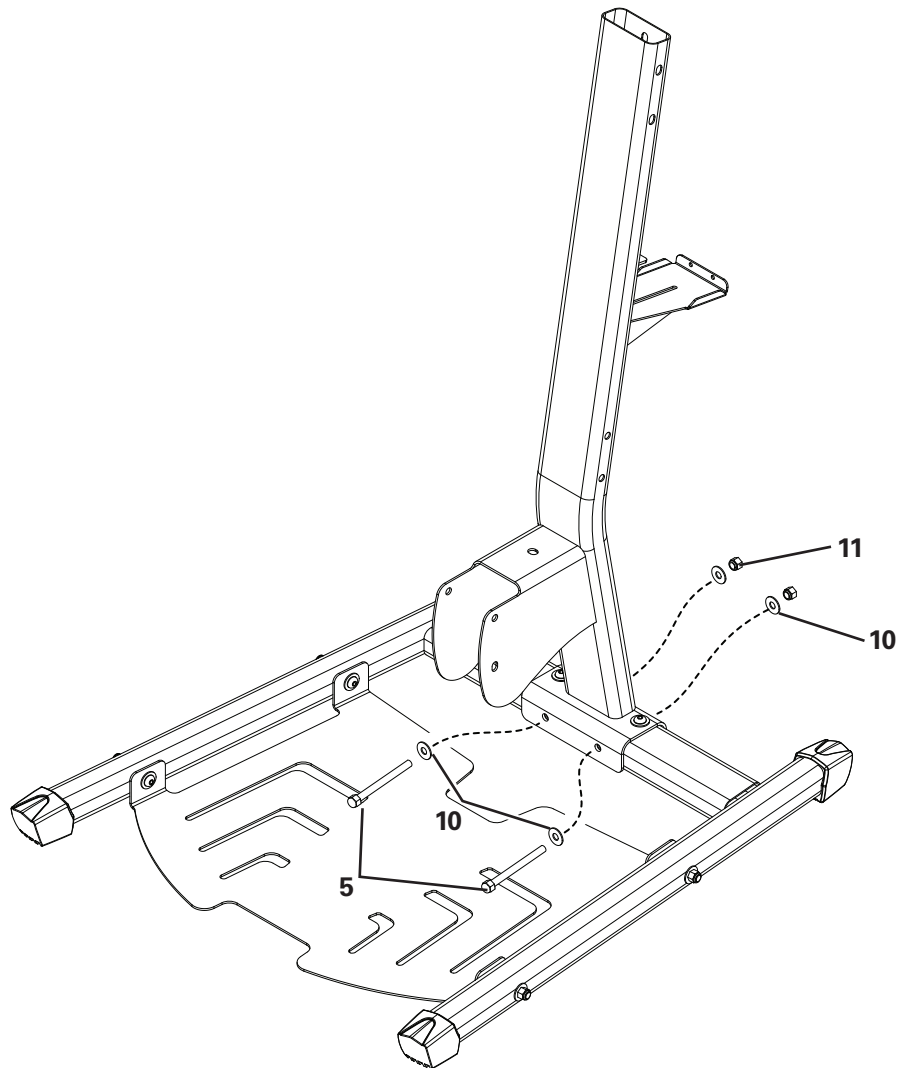



# Assembly

## Step 3: Assemble the Seat Rail

### Parts

- Seat Rail (#23)
- Seat Cushion (#20)
- Seat Slider (#36)

### Hardware

- (4) 5/16" x 3/4" Hex Head Bolts (#1)
- (4) 5/16" Washers (#9)
- (1) Rubber Pad (#38)

### Tools

- Adjustable Wrench (not included)

**3-1** Slide the Seat Slider onto the Seat Rail.

**Note:** The threaded hole on the end of the Seat Rail must face upward.

**3-2** Attach the Seat Cushion to the Seat Slider with the Hex Head Bolts and Washers. Tighten hardware.

**3-3** Apply the Rubber Pad to the upper end of the Seat Rail.

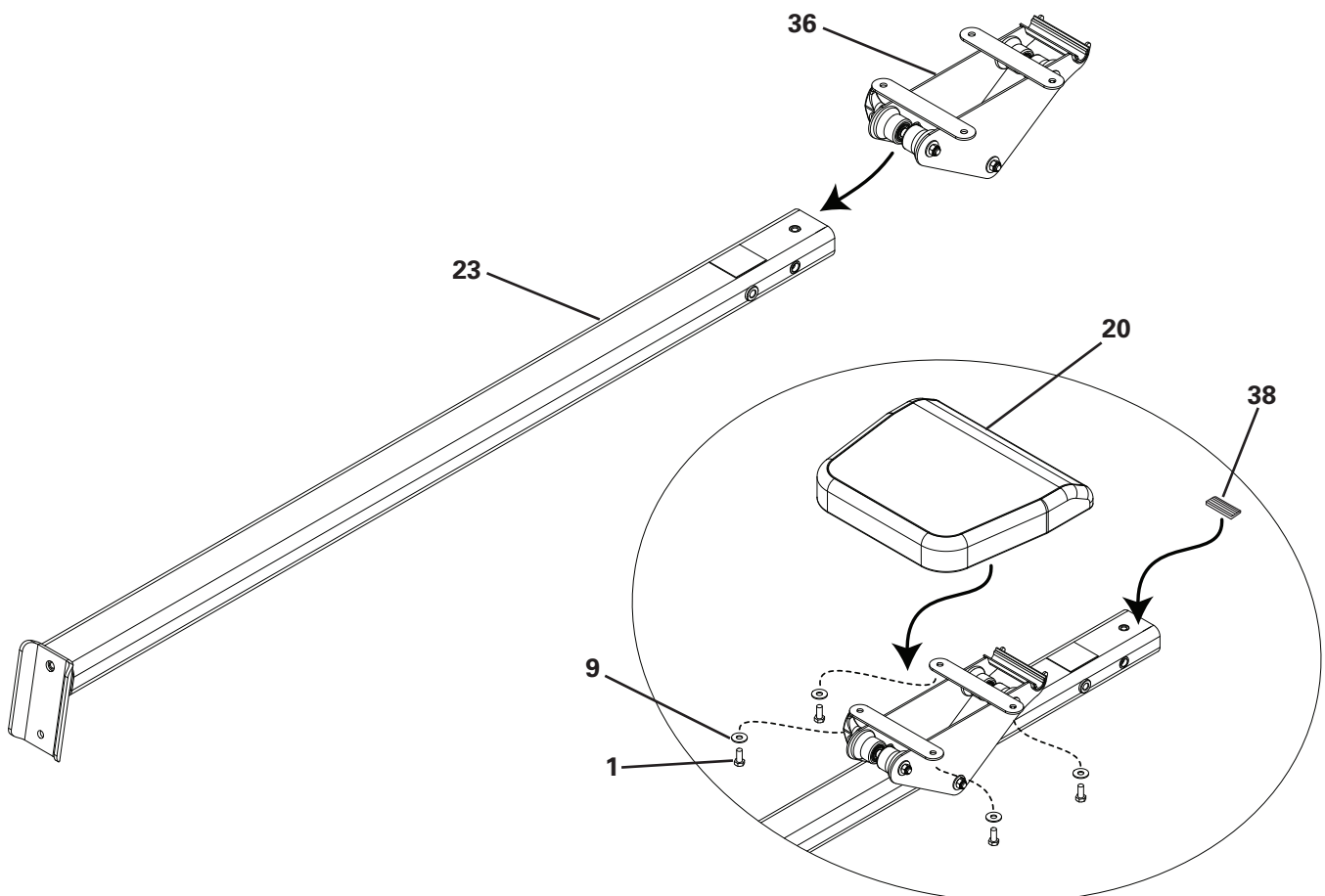

# Assembly

## Step 4: Assemble the Leg Extension

### Parts

- Leg Extension (#24)
- Leg Extension Cross Tube (#25)

### Hardware

- (2) 3/8" x 3" Hex Head Bolt (#4)
- (4) 3/8" Washers (#10)
- (2) 3/8" Nut (#11)

### Tools

- (2) Adjustable Wrenches (not included)

**4-1** Set the bracket end of the Leg Extension onto the Leg Extension Tube and align the bolt holes.

**4-2** Install and tighten the hardware.

**Note:** Do not unwrap the cable from the pulley.

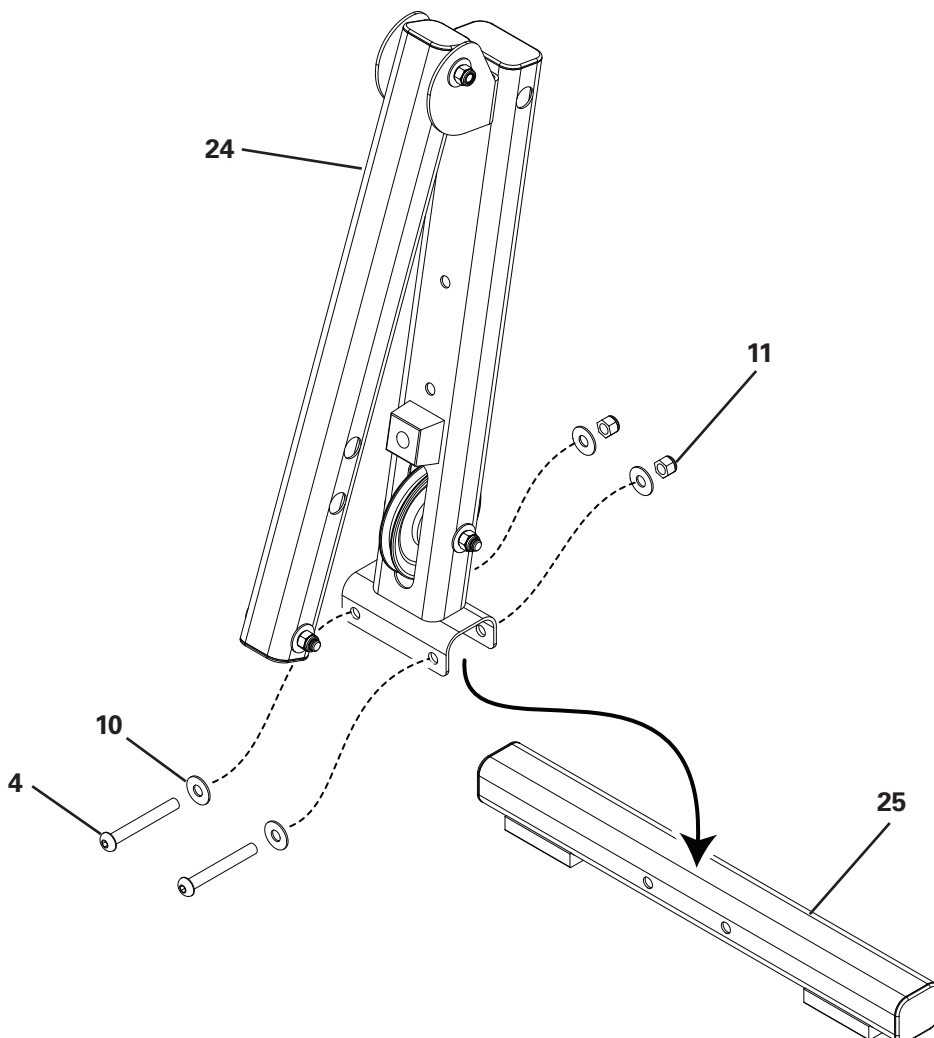

# Assembly

## Step 5: Attach the Seat Rail to the Leg Extension

### Parts

- Seat Rail Assembly (from step 3)
- Leg Extension Assembly (from step 4)

### Hardware

- (2) 3/8" x 2 3/4" Hex Head Bolt (#3)
- (3) 3/8" Washers (#10)
- (1) 3/8" Nut (#11)

### Tools

- (2) Adjustable Wrenches (not included)

**5-1** Align the bolt holes of the Seat Rail Assembly with the bolt holes in the Leg Extension Assembly.

**5-2** Install and tighten the hardware.

**Note:** Do not unwrap the cables from the pulleys.

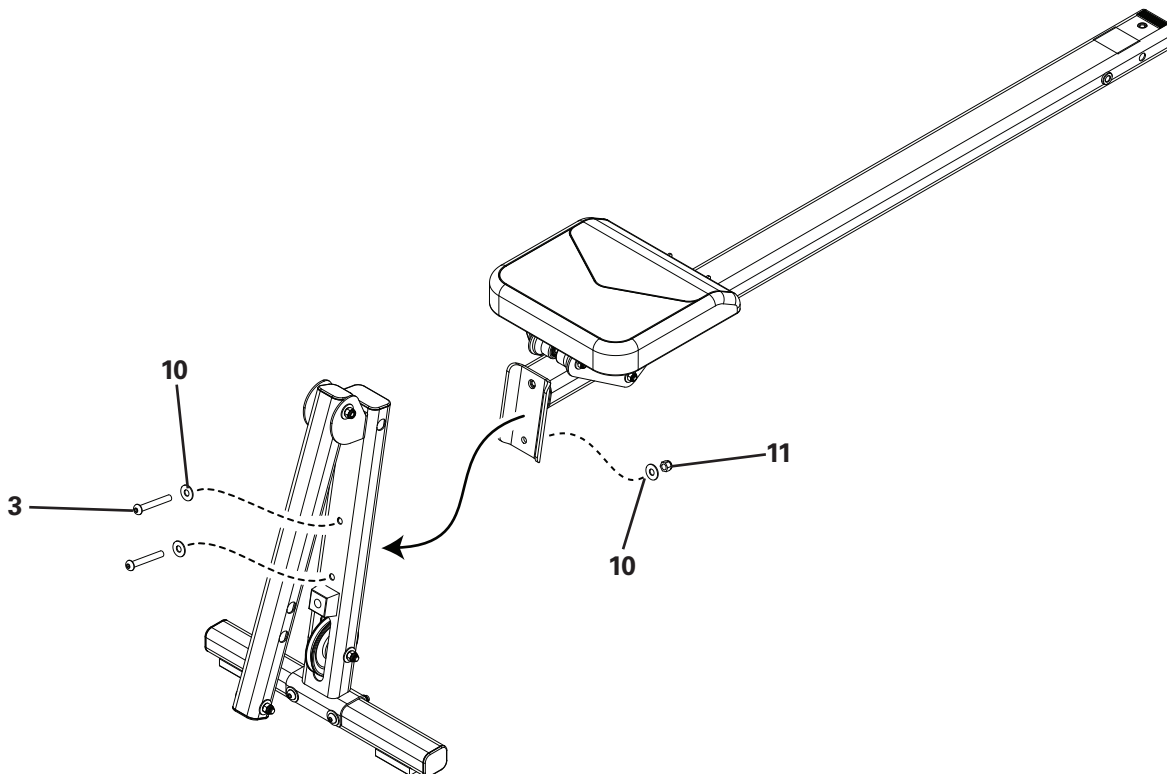

# Assembly

## Step 6: Attach the Seat Rail to the Base Assembly

### Parts

- Seat Rail Assembly (from step 5)
- Completed Assembly (from step 2)

### Hardware

- (1) 3/8" x 4 1/4" Hex Head Bolt (#12)
- (2) 3/8" Washers (#10)
- (1) 3/8" Nut (#11)
- (1) Threaded Knob (#35)

### Tools

- (2) Adjustable Wrenches (not included)

**6-1** Insert the Seat Rail Assembly into the Lower Lat Tower Assembly.

**6-2** Install and tighten the hardware.

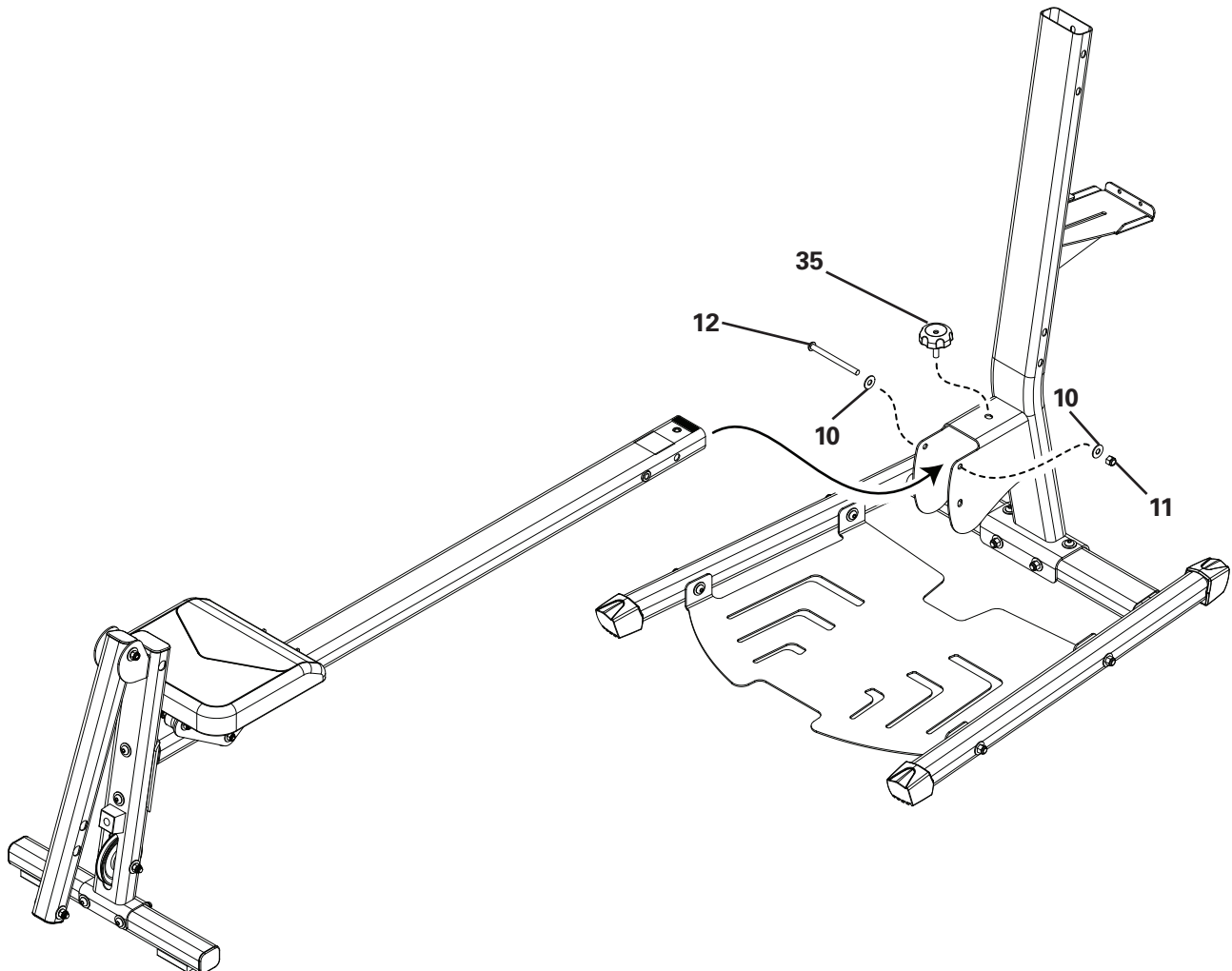

# Assembly

## Step 7: Upper Lat Tower

### Parts

- Upper Lat Tower
- Lat Tower Cross Bar with Pulleys and Cables

### Hardware

- (2) 3/8" x 3" Hex Head Bolt (#4)
- (4) 3/8" Washers (#10)
- (2) 3/8" Nut (#11)

### Tools

- (2) Adjustable Wrenches (not included)

**7-1** Align the Lat Tower Cross Bar bolt holes with the bolt holes in the Upper Lat Tower bracket.

**7-2** Install and tighten the hardware.

**Note:** Do not unwrap the cables from the pulleys.

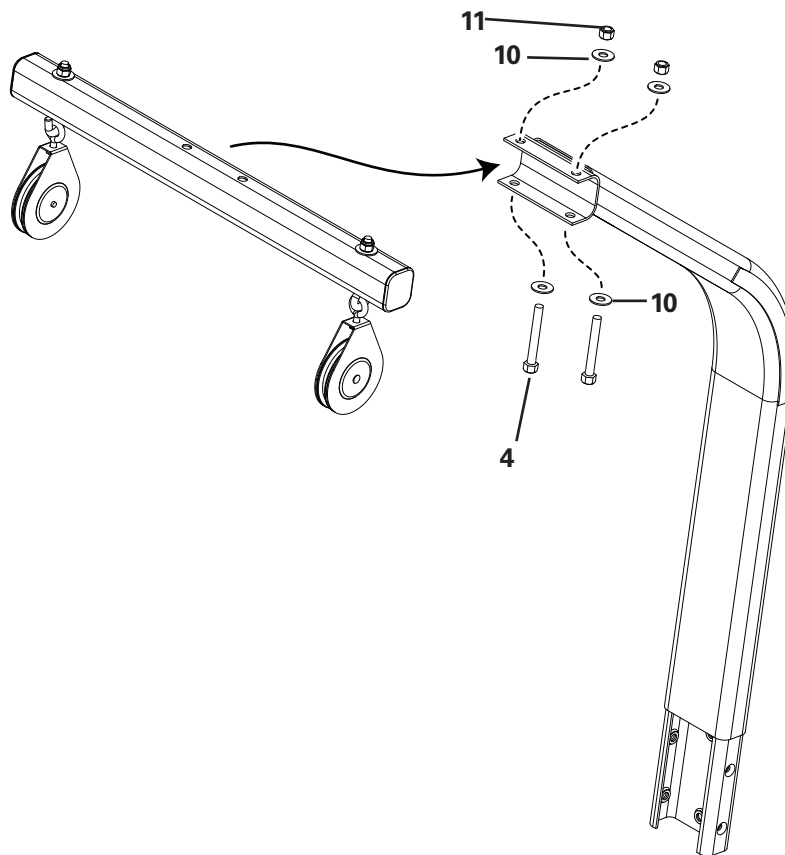

# Assembly

## Step 8: Attach the Upper Lat Tower to the Base Assembly

### Parts

- Upper Lat Tower Assembly (from step 7)
- Completed Assembly (from step 6)

### Hardware

- (6) 3/8" x 3/4" Hex Head Bolt (#2)
- (6) 3/8" Washers (#10)

### Tools

- (2) Adjustable Wrenches (not included)

**8-1** Insert the Upper Lat Tower Assembly into the Lower Lat Tower.

**8-2** Install and tighten the hardware.

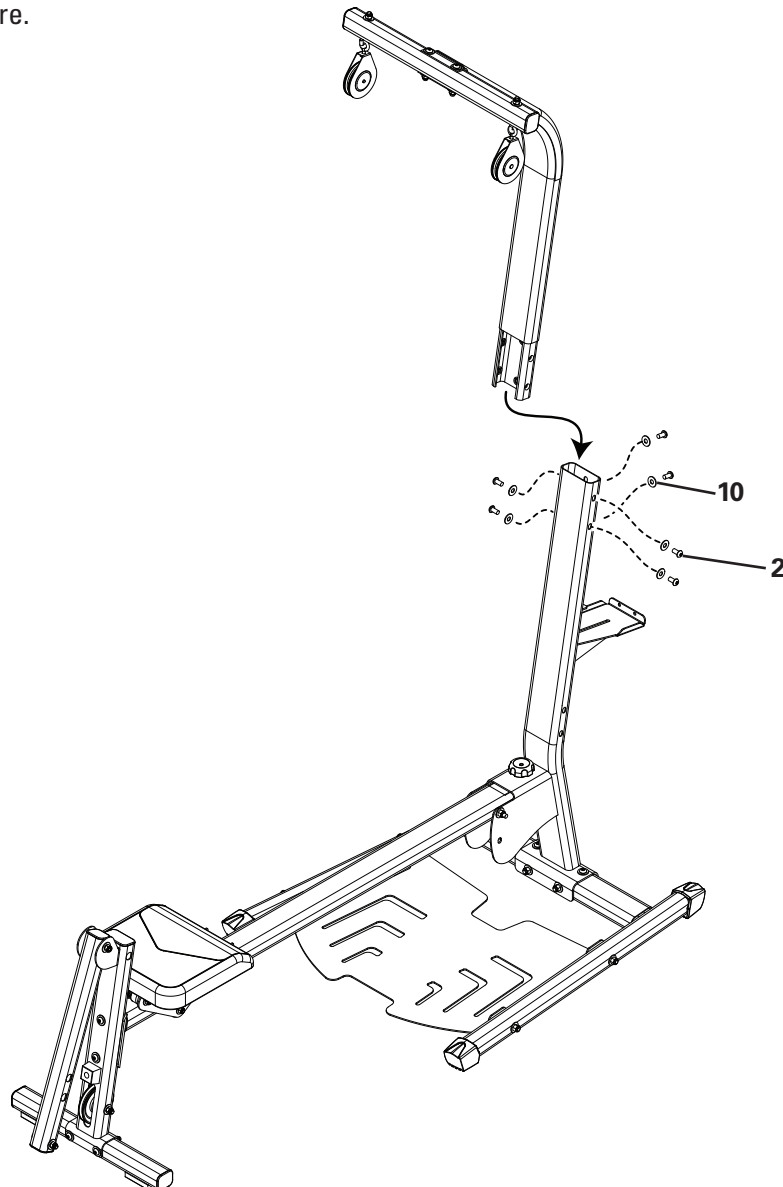

# Assembly

## Step 9: Apply the Cable Clip

### Parts

- (1) Cable Clip (#39)
- Completed Assembly (from step 8)

**9-1** Apply the Cable Clip to the rear of the Lower Lat Tower.

**Note:** Be sure to use the cable clip when the cables are not in use.

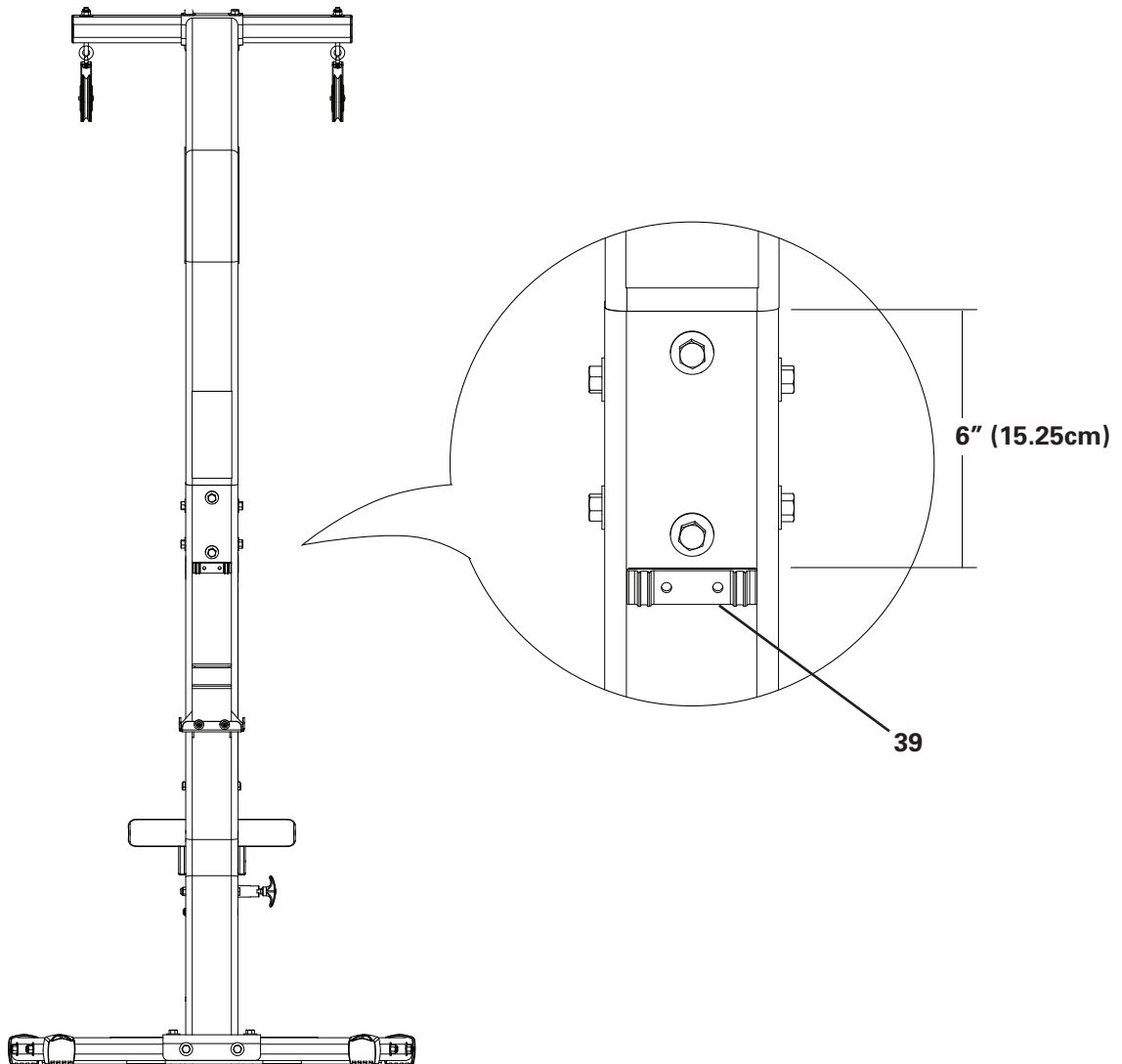

# Assembly

## Step 10: Attach the Rod Pack

### Parts

- Completed Assembly (from step 9)
- (1) Bowflex® Rod Pack (#26)
- (1) Rod Box End Plate (#31)

### Hardware

- (3) #10 x 1" Self Tapping Screws (#7)
- (2) 1/4" x 1" Phillips Head Bolt (#13)
- (5) 1/4" Washers (#8)

### Tools

- Phillips Head Screw Driver (not included)

**10-1** Slide the Bowflex® Rod Pack into the Rod Pack Holder.

**10-2** Install and completely tighten the hardware.

**Note:** Make sure that the hardware is tightly secured.

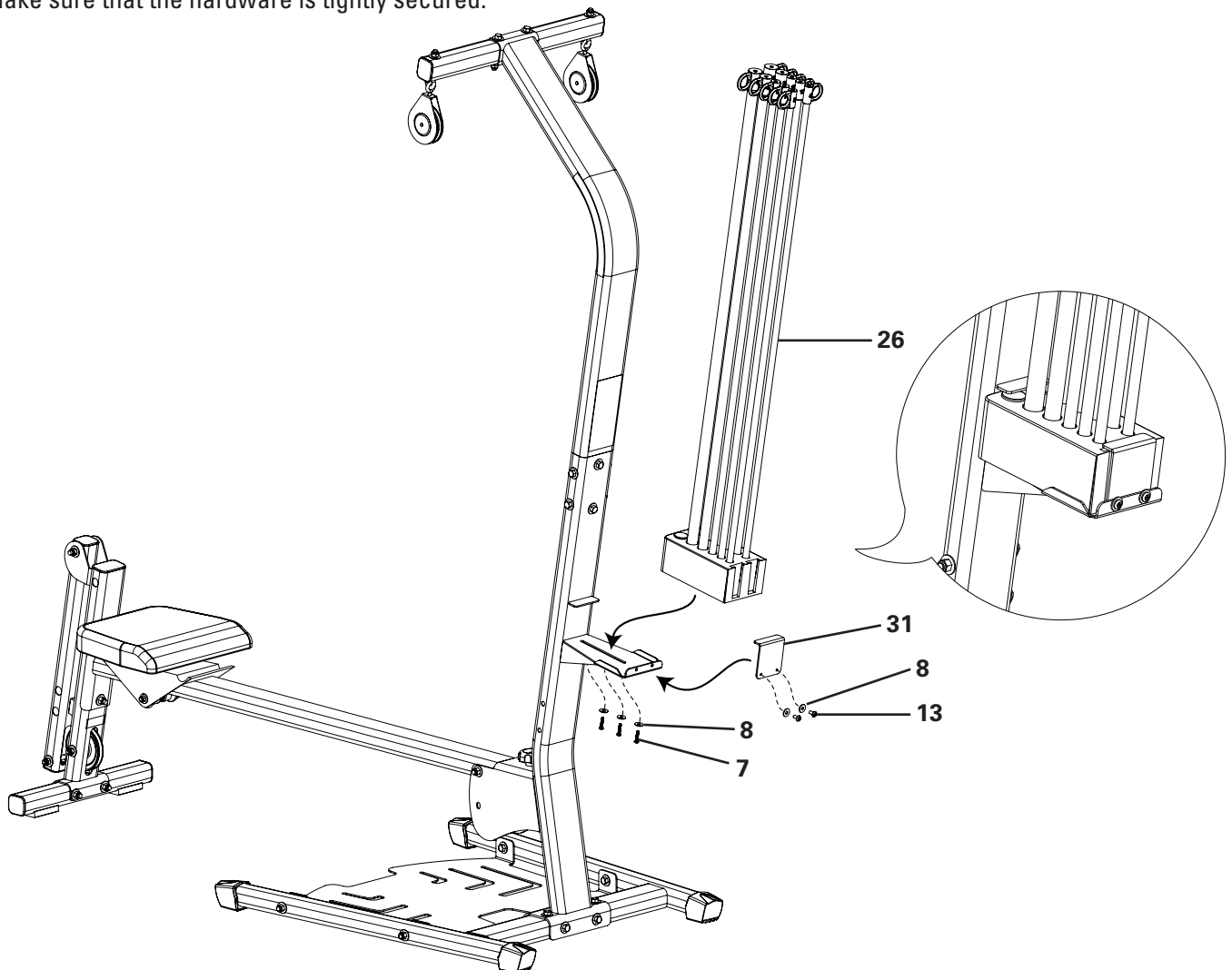



# Assembly

## Step 11: Chest Bar with Pulleys

### Parts

- Completed Assembly (from step 10)
- Chest Bar with Pulleys and Cables (#22)

### Hardware

- (2) 3/8" x 5" Hex Head Bolts (#6)
- (4) 3/8" Washers (#10)
- (2) 3/8" Nuts (#11)

### Tools

- (2) Adjustable Wrenches (not included)

**11-1** Attach the Chest Bar with Pulleys and Cables to the Lower Lat Tower.

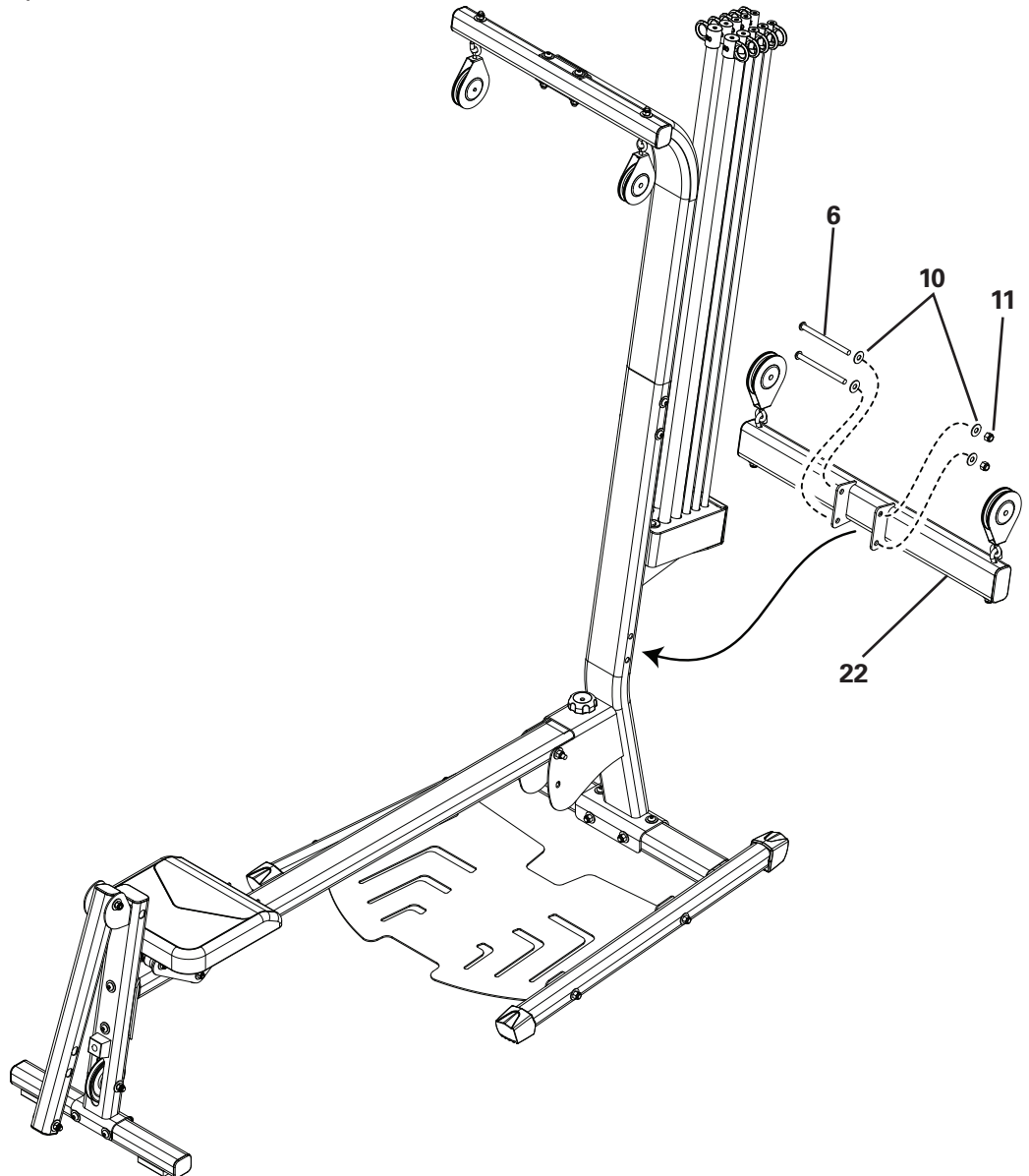

# Assembly

## Step 12: Leg Extension Rollers

### Parts

- (4) Foam Roller Pads (#27)
- (4) Tube End Plugs (#33)
- (1) Long Roller Tube (#29)
- (1) Short Roller Tube (#28)
- Completed Assembly (from step 11)

**12-1** Insert the Roller Tubes through the Leg Extension.

**12-2** Slide the Foam Rollers onto the Roller Tubes.

**12-3** Plug the Roller Tube ends with the Tube End Plugs.

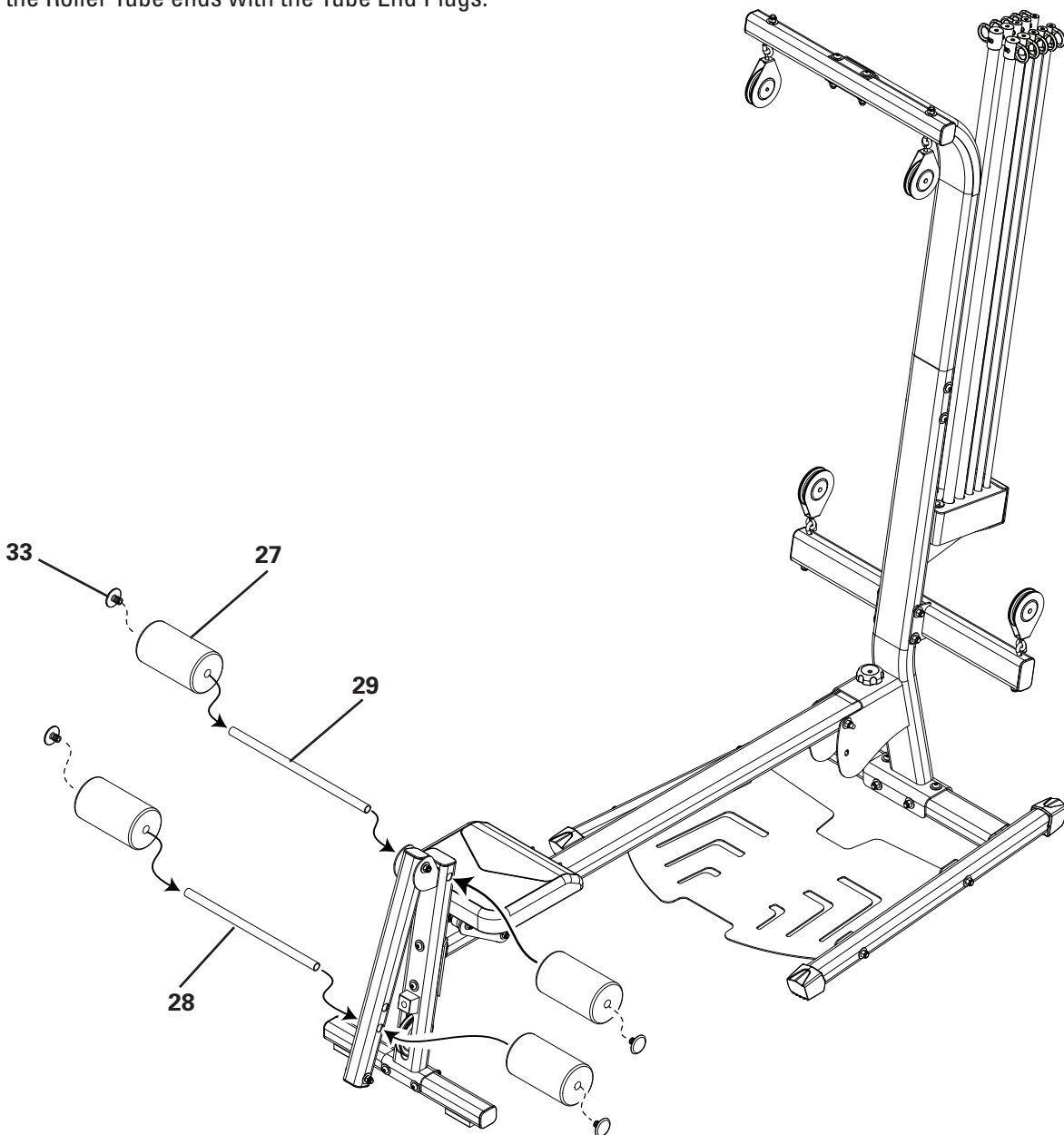

# Assembly

## Step 13: Attach the Bench

### Parts

- Bench Cushion (#16)
- Completed Assembly (from step 12)

13-1 Put the Bench Cushion onto the Seat Rail and the Seat Slider.

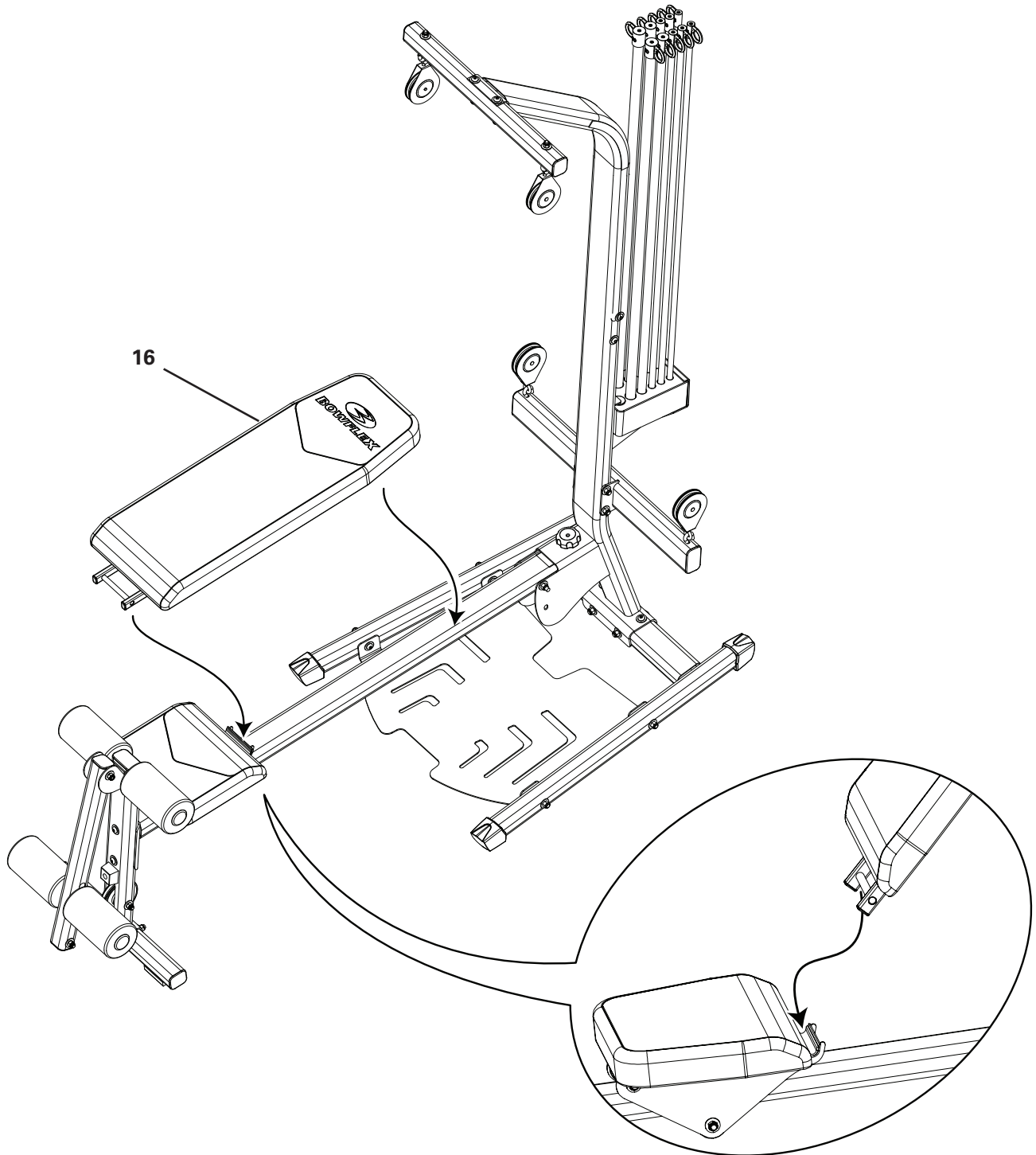

# Assembly

## Step 14: Attach Placard

### Parts

- Exercise Placard (#30)
- Completed Assembly (from step 13)

**14-1** Snap the Exercise Placard onto the upper Lat Tower.

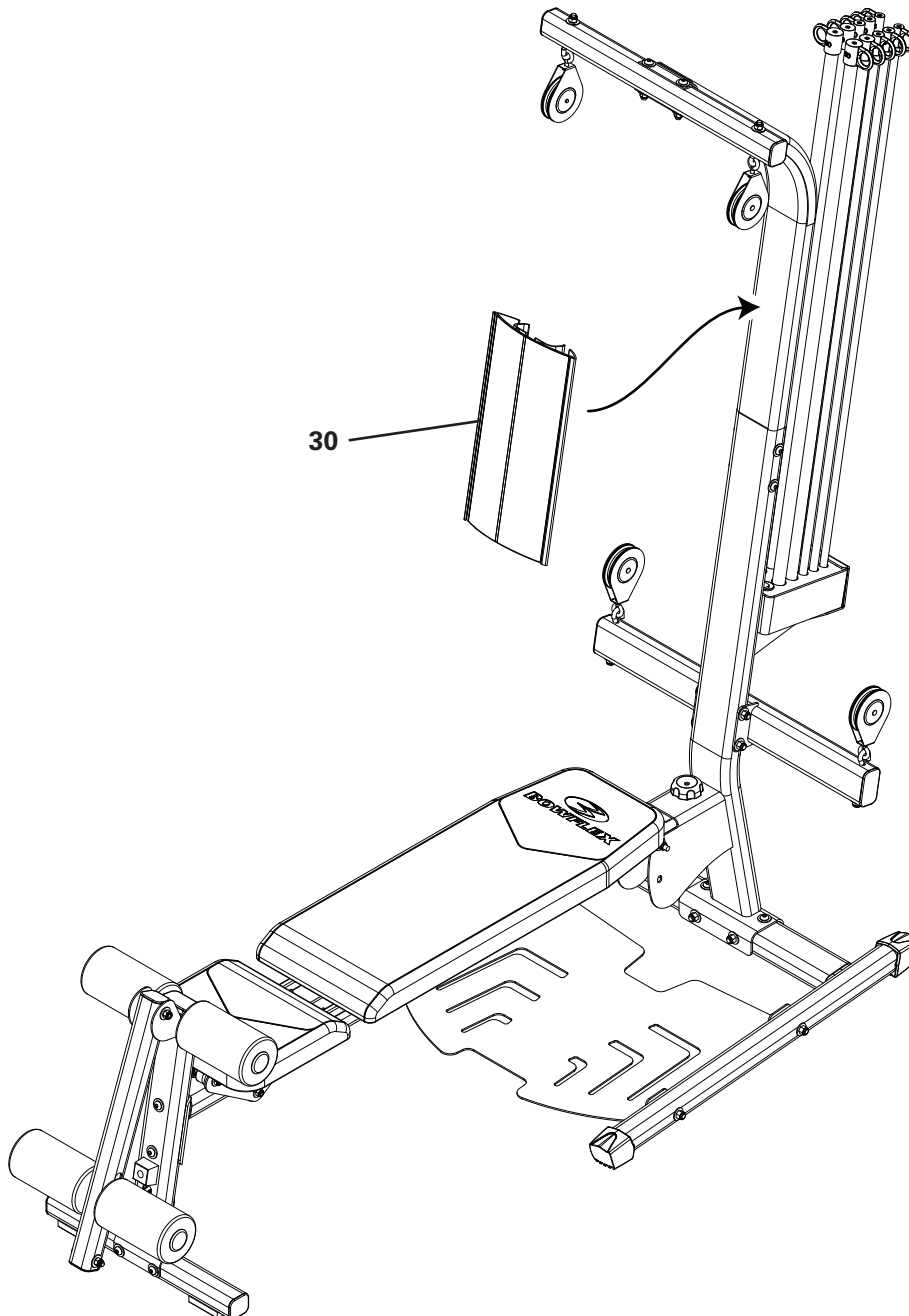

# Assembly

## Step 15: Level the Machine

### Parts

- Completed Assembly (from step 14)

### Tools

- (2) Adjustable Wrenches (not included)

**15-1** Loosen but do not remove the bolts on the foot plate.

**15-2** Stand on the foot plate until it rests flat on the floor.

**15-3** Re-tighten the bolts.

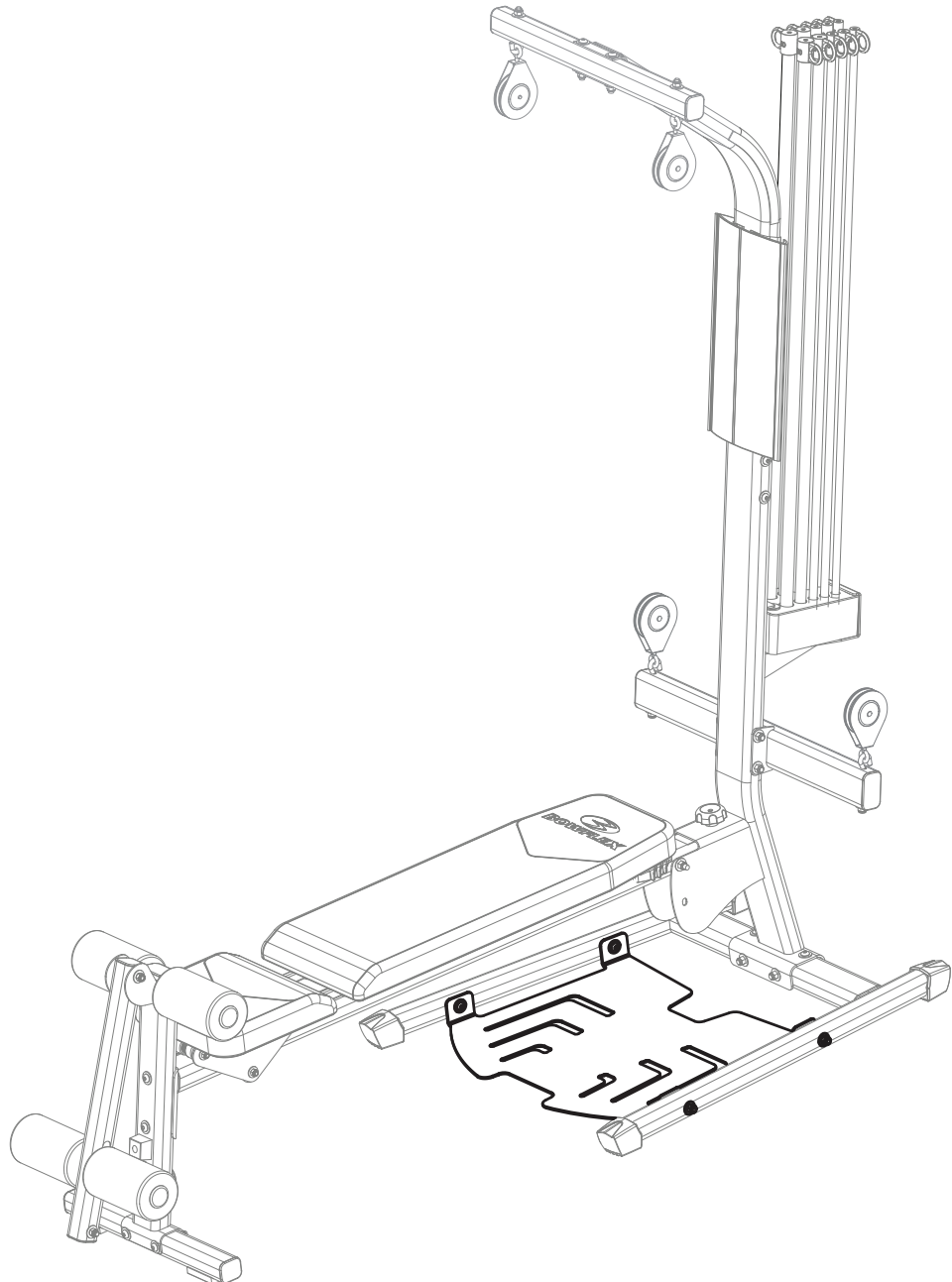

# Assembly

## Step A: Connect the Cables to the Power Rod® Unit, Chest Bar, and Handgrips

### Parts

- (2) Handgrips (#15)

**A-1** Remove the plastic and unwrap the cables from the Chest Bar Pulleys.

**A-2** Attach the Rod Hooks to the Power Rod® Unit.

**A-3** Connect the Handgrips to the Snap Hooks on the Cables.

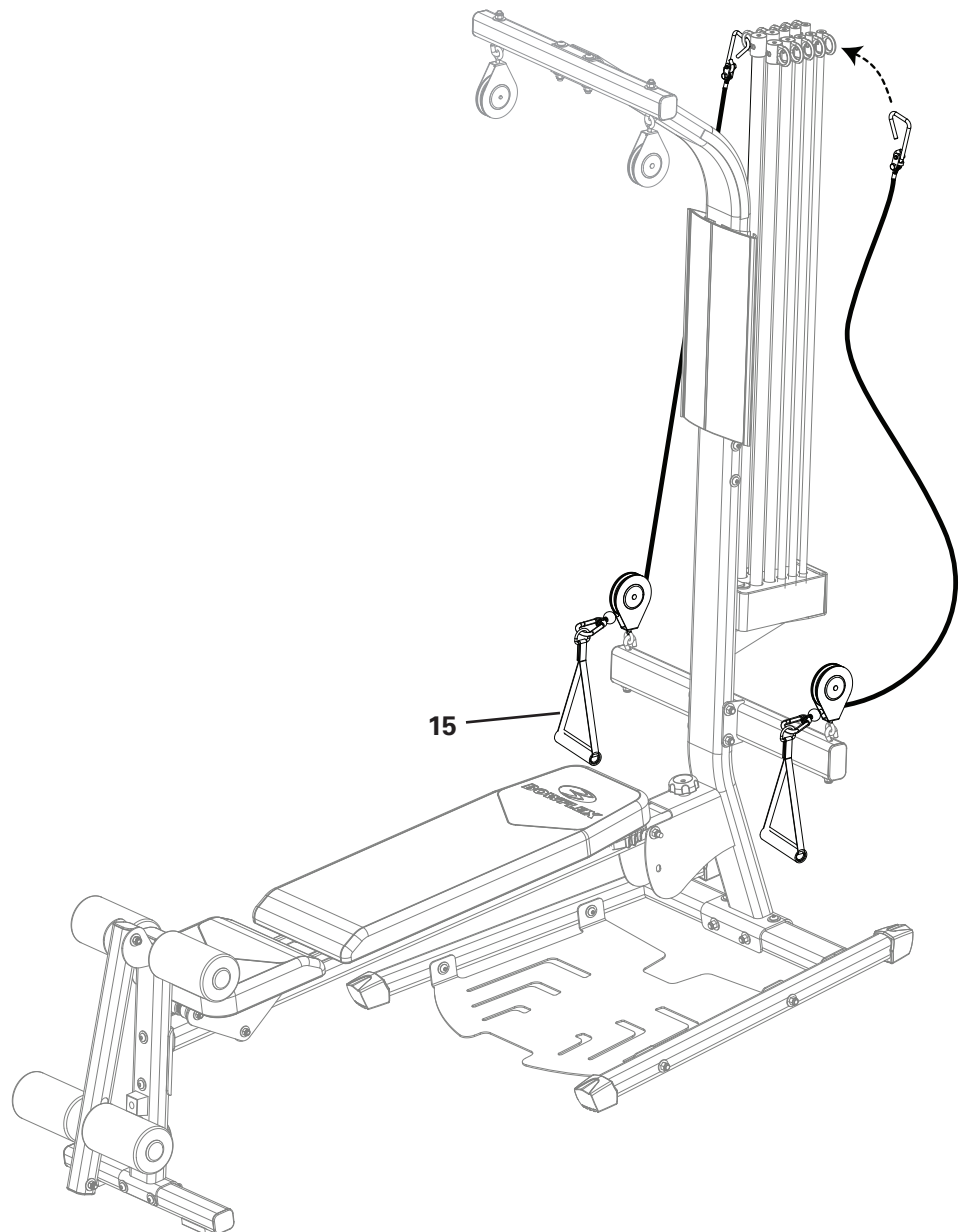

# Assembly

## Step B: Connect the Cables from the Chest Bar and Lat Cross Bar to the Handgrips

### Parts

- (2) Handgrips (#15)

**B-1** Remove the plastic and unwrap the cables from the Lat Bar Pulleys.

**B-2** Attach the Snap Hooks from the Chest Bar Pulleys to the Cables on the Lat Cross Bar.

**B-3** Attach the Handgrips to the Snap Hooks from the Lat Cross Bar.

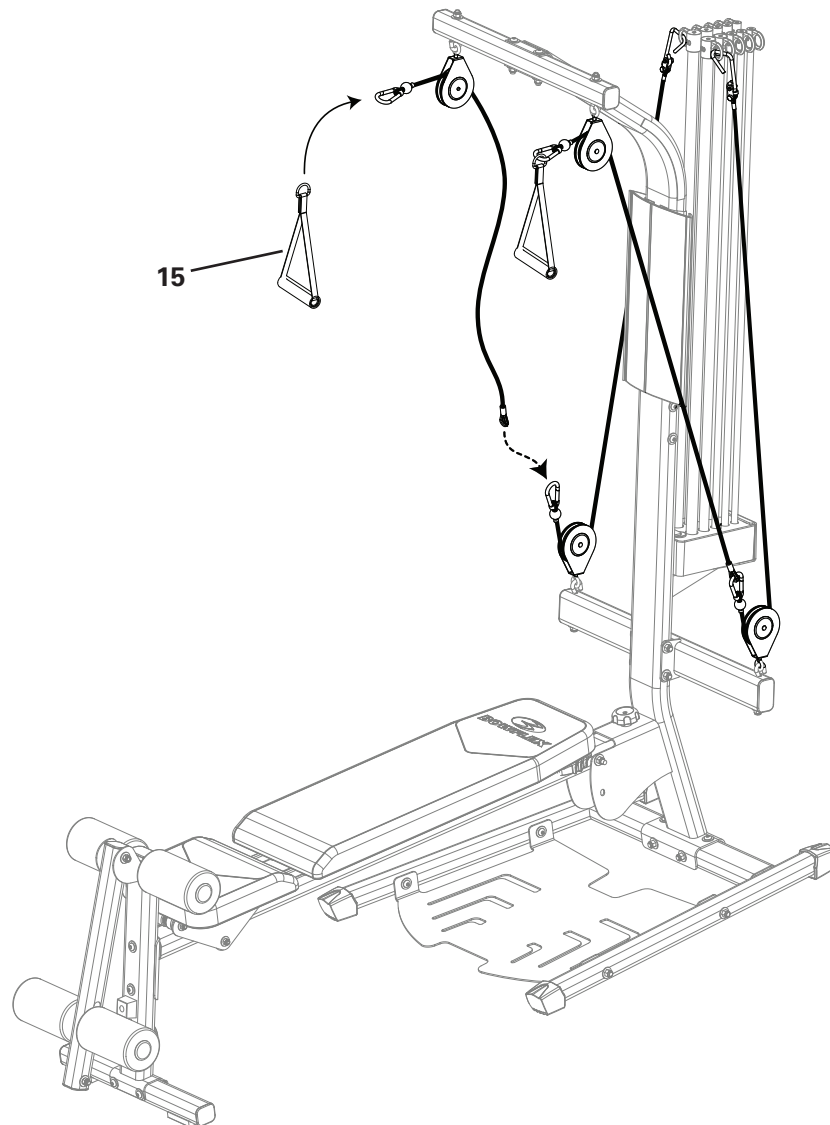

# Assembly

## Step C: Connect the Cables from the Chest Bar to the Leg Extension

**C-1** Remove the plastic and unwrap the cables from the Leg Extension Pulleys.

**C-2** Attach the Snap Hooks from the Chest Bar Pulleys to the Leg Extension Cables.

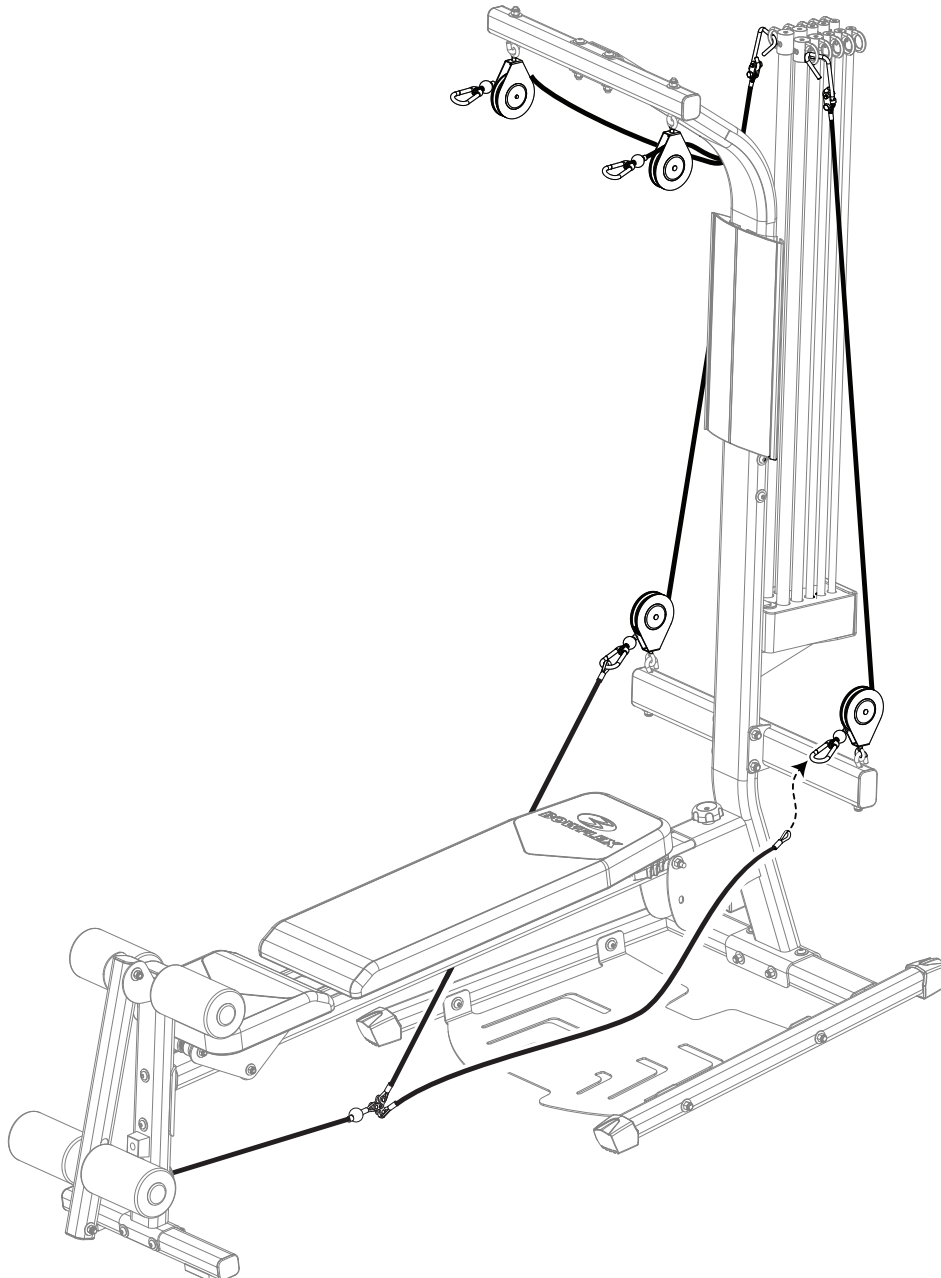

## Final Inspection

Inspect your machine to ensure that all fasteners are tight and components are properly assembled.



Do not use until the machine has been fully assembled and inspected for correct performance in accordance with the Owner's Manual.











Nautilus, Inc., (800) NAUTILUS / (800) 628-8458, [www.NautilusInc.com](http://www.NautilusInc.com) - Customer Service: North America (800) 605-3369, [csnls@nautilus.com](mailto:csnls@nautilus.com) | outside U.S. +01-360-859-5180, [technics-APLA@nautilus.com](mailto:technics-APLA@nautilus.com) | Printed in China | © 2008 Nautilus, Inc..

Nautilus®

Bowflex®

Schwinn® Fitness

Universal®